

, LK117,

LK; 1-1, 1-
2~11 -

DP.

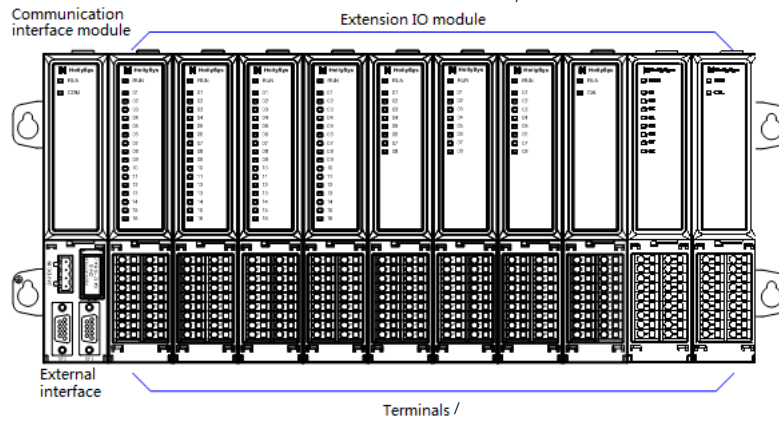

1-1

LK117

. 1-2,

DP

DP.

DP

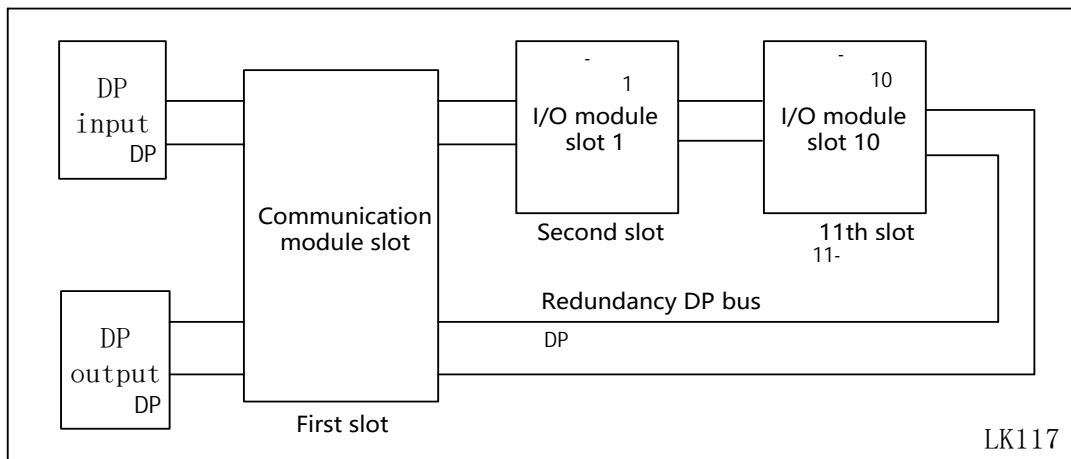

1-2

LK117

LK117

11

- 1 , 10 -
- Profibus-DP, DB9
- 24 , 4-
-
-
-

LK117		11	
	11	(1	, 10 -)
Profibus-DP	DB9,		
	4-		24
	1000	1	: 5
	1000	1	: 5
	24	(-15%~20%) 24	(-15%~20%)
(* *)	385	× 166	× 55,5
	IEC60529 IP20		
	1740		
	0°C~60°C		
	5%~95%,		
	-40°C~70°C		
	5%~95%,		

LK118

5

- 1 , 4 -

●
●
●
●
●

LK118 - Profibus-DP, 9- 24 , 4- D.
1- 5 , 1-3, ,
4 - ; 2-5 - DP.

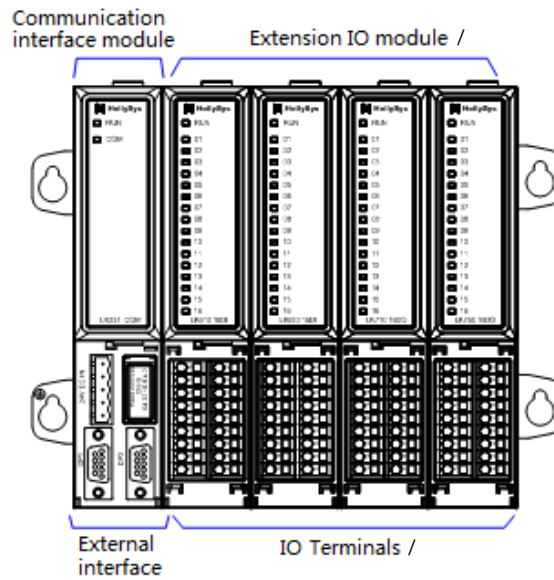

1-3

LK118

LK118

1-4.

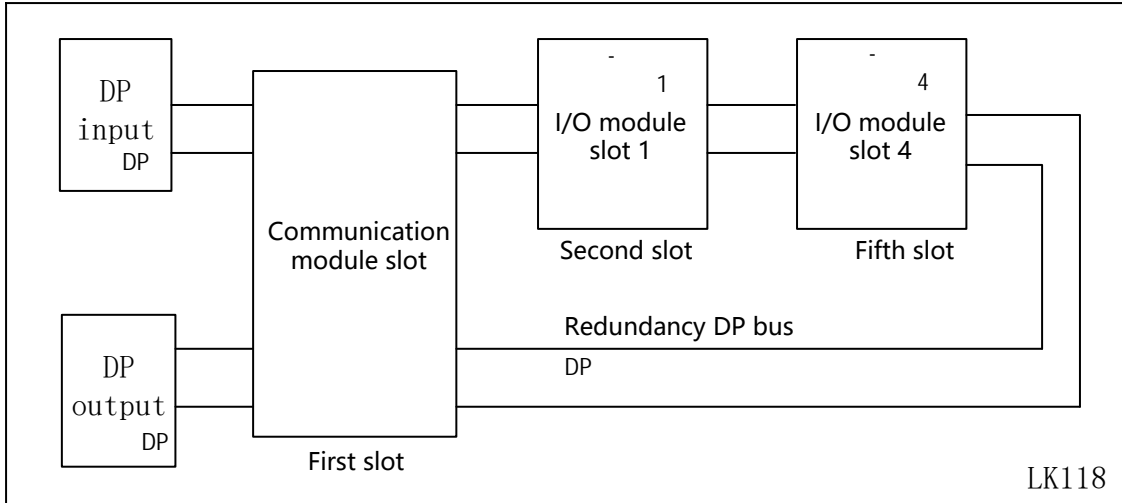

1-4

LK118		5	
Profibus-DP		5 (1, 4, -))
		DB9,	
		4-	24
		500	1, : 5
		500	1, : 5
		24	(-15%~20%) 24 (-15%~20%)
		210 × 166 × 55	
		IEC60529 IP20	
		1740	
		0°C~60°C	
		5%~95%,	
		-40°C~70°C	
		5%~95%,	