

# LK412 6-

- 6-
- : 0~20 / 4~20 / -10 ~10 / 0 ~ 10 / 0~ 5
- : 0~20,58 / 4~20,58 / -10,25 ~10,25 /
- 0~10,25 / 0~5,125
- 
- 
- 
- 
- 
- 
- 
- 

24 LK412 = 15 24 DC/DC  
 ( ),  
 DP. / , , A/ , DP.  
 A/ ,

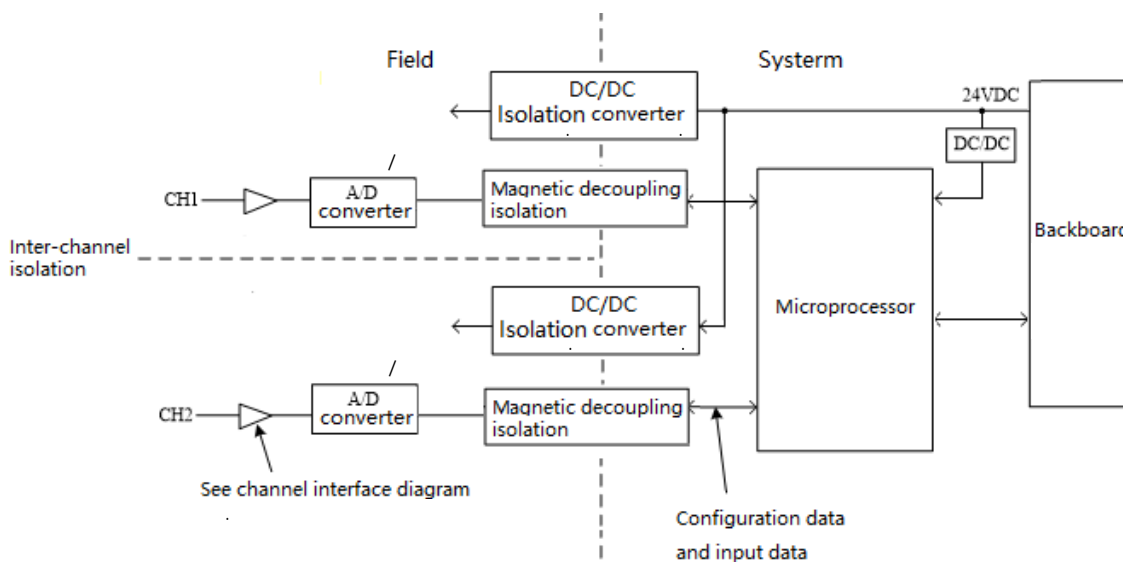

1-1 -

LK412

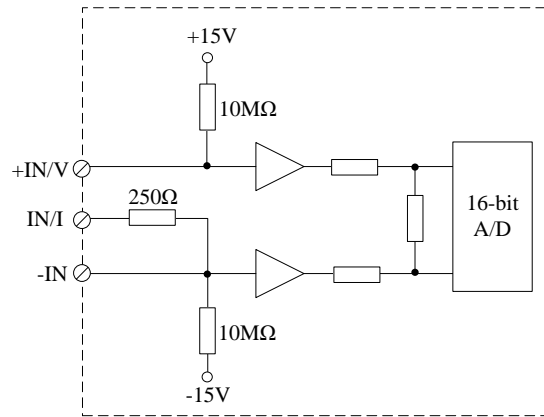

1-2

LK412

| LK412 6- |   |              |          |          |          |
|----------|---|--------------|----------|----------|----------|
|          |   | 20,4 ~27,6   |          |          |          |
| ( . )    |   | 150          | 24       |          |          |
|          |   | 6            |          |          |          |
|          |   | 16           | 17       | 18       |          |
| .        | - | -10.25~0     | 0~10.25  | 0~10.25  | 0~5.125  |
|          |   | 32768~65,535 | 0~32,767 | 0~65,535 | 0~65,535 |
|          |   | 70           |          | 71       |          |
| .        |   | 0~20.58      |          | 4~20.58  |          |
|          |   | 0~65,535     |          | 0~65,535 |          |
|          | - | >1 MΩ        |          |          |          |
|          |   | 250 Ω        |          |          |          |
|          |   | 16-          |          |          |          |
| ( . )    |   | <50          |          |          |          |
|          |   | >60          |          |          |          |
|          |   | >90          |          |          |          |

|          |                    |
|----------|--------------------|
| LK412 6- |                    |
|          | 0.1% F.S.          |
|          | 0.02% F.S.         |
| (25°C)   | 0.03% F.S.         |
|          | 12                 |
|          | 90% , 1            |
|          | ±25 ppm/°C         |
|          | 0x02;              |
|          | /<br>0xA3/0xA2     |
|          | /<br>0xA7/0xA8     |
|          | 0xA0 0x06;         |
|          | 5 1 500            |
|          | 5 1 500            |
|          | A0                 |
|          | LK<br>= 35 100 100 |
|          | IEC60529 IP20      |
|          | 190                |
|          | 5%~95%,            |
|          | -40°C~70°C         |
|          | 5%~95%,            |
|          | 0°C~60°C           |